

ITEM NO.	PART NUMBER	DESCRIPTION	QTY
1	M12x1.75X110 SHCS	MCMaster P/N 91290A642	3
2	3-891-610P	FULL OEM JAW REPLACEMENT SET, 10IN, 6-JAW	6
3	3-889-012P	WRENCH FOR 10IN & 12IN SCROLL CHUCK	1
4	3-886-310P	PINION FOR 10IN SCROLL CHUCK	3
5	C-CK10-BDY6JFM	CHUCK BODY, 10IN	1
6	3-809-906P	FITTING, GREASE	1
7	3-887-310P	SCROLL PLATE FOR 10IN CHUCK	1
8	3-888-910P	PINION SCREW FOR 8, 10 OR 12in CHUCK	3
9	C-CK10-COVER	PLATE, COVER, MACHINED	1
10	3-899-310P	SHCS, M8x1.25X16	3
11	3-897-610P	FINE ADJUSTMENT SCREW, M18x1 FOR 10in SET-TRU	4
12	C-CK10-MODULE	MODULE, SET-TRU, 10IN	1
13	M12x1.75X30 SHCS	MCMaster P/N 91290A618	3

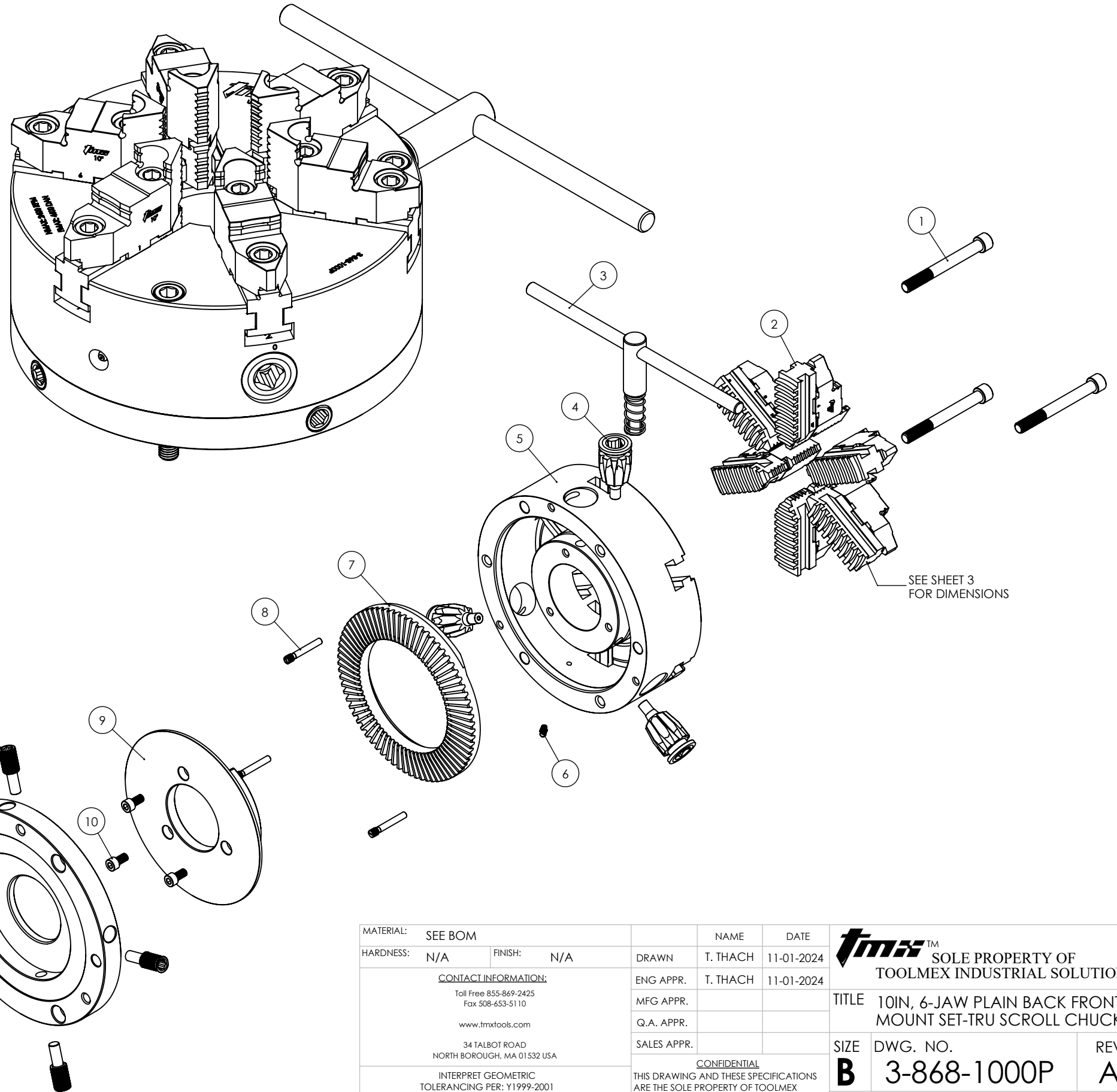

-CLICK ON LINK BELOW FOR REPLACEMENT PARTS-

WWW.TOOLMEX.COM

SELLING UNIT: EACH
 CHUCK TYPE: SCROLL
 CHUCK SIZE: 10IN
 BODY MATERIAL: FORGED STEEL
 NUMBER OF JAWS: 6
 JAW TYPE: 2 PIECES
 WEIGHT: 81 LBS
 MOUNT TYPE: FRONT
 GRIPPING FORCE: 4600 daN
 SPEED: 2400 RPM Max.

MATERIAL:	SEE BOM	NAME	T. THACH	DATE	11-01-2024
HARDNESS:	N/A	FINISH:	N/A	DRAWN	T. THACH
<u>CONTACT INFORMATION:</u> Toll Free 855-869-2425 Fax 508-653-5110 www.tmxtools.com 34 TALBOT ROAD NORTH BOROUGH, MA 01532 USA			ENG APPR.	T. THACH	11-01-2024
INTERPRET GEOMETRIC TOLERANCING PER: Y1999-2001			MFG APPR.		
 THIRD ANGLE PROJECTION			Q.A. APPR.		
CONFIDENTIAL THIS DRAWING AND THESE SPECIFICATIONS ARE THE SOLE PROPERTY OF TOOLMEX INDUSTRIAL SOLUTIONS, AND SHALL NOT BE REPRODUCED, OR COPIED IN PART OR AS A WHOLE WITHOUT THE EXPRESS WRITTEN PERMISSION OF TOOLMEX INDUSTRIAL SOLUTIONS IS PROHIBITED.			SALES APPR.		
Tmx ™ SOLE PROPERTY OF TOOLMEX INDUSTRIAL SOLUTIONS		TITLE	10IN, 6-JAW PLAIN BACK FRONT MOUNT SET-TRU SCROLL CHUCK		
SIZE	DWG. NO.	REV			
B	3-868-1000P	A	UNITS IN MILLIMETER		
DO NOT SCALE DRAWING		SHEET 1 OF 3			

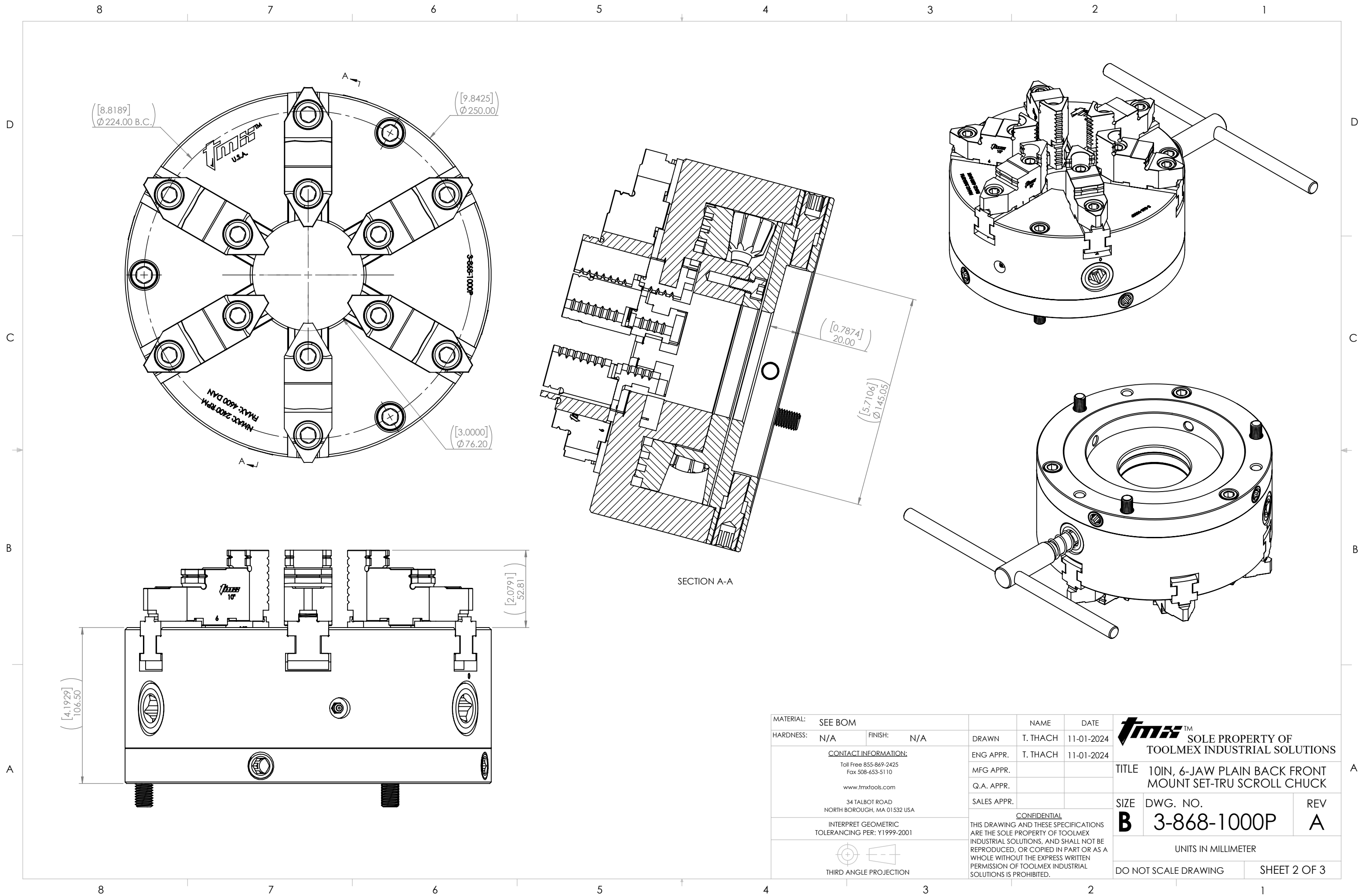

MATERIAL:	SEE BOM	NAME	T. THACH	DATE	11-01-2024
HARDNESS:	N/A	FINISH:	N/A	DRAWN	T. THACH
<p>CONTACT INFORMATION: Toll Free 855-869-2425 Fax 508-653-5110 www.tmxtools.com 34 TALBOT ROAD NORTH BOROUGH, MA 01532 USA</p>			ENG APPR.	T. THACH	11-01-2024
<p>INTERPRET GEOMETRIC TOLERANCING PER: Y1999-2001</p>			MFG APPR.		
<p>THIRD ANGLE PROJECTION</p>			Q.A. APPR.		
<p>CONFIDENTIAL THIS DRAWING AND THESE SPECIFICATIONS ARE THE SOLE PROPERTY OF TOOLMEX INDUSTRIAL SOLUTIONS, AND SHALL NOT BE REPRODUCED, OR COPIED IN PART OR AS A WHOLE WITHOUT THE EXPRESS WRITTEN PERMISSION OF TOOLMEX INDUSTRIAL SOLUTIONS IS PROHIBITED.</p>			SALES APPR.		
<p>TOOLMEX™ SOLE PROPERTY OF TOOLMEX INDUSTRIAL SOLUTIONS</p>		TITLE	10IN, 6-JAW PLAIN BACK FRONT MOUNT SET-TRU SCROLL CHUCK		
SIZE	DWG. NO.	REV			
B	3-868-1000P	A			
UNITS IN MILLIMETER					
DO NOT SCALE DRAWING			SHEET 2 OF 3		

8 7 6 5 4 3 2 1

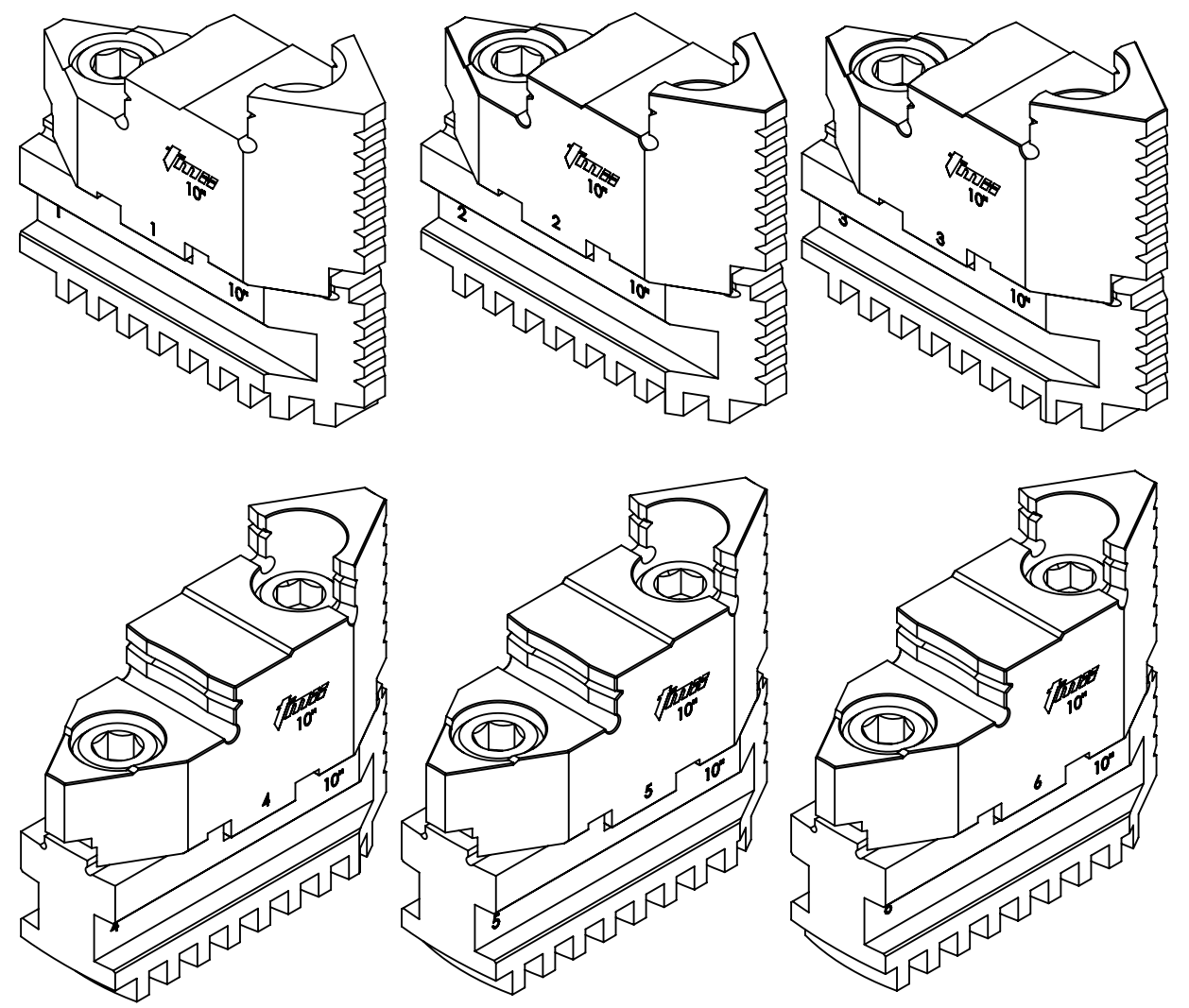
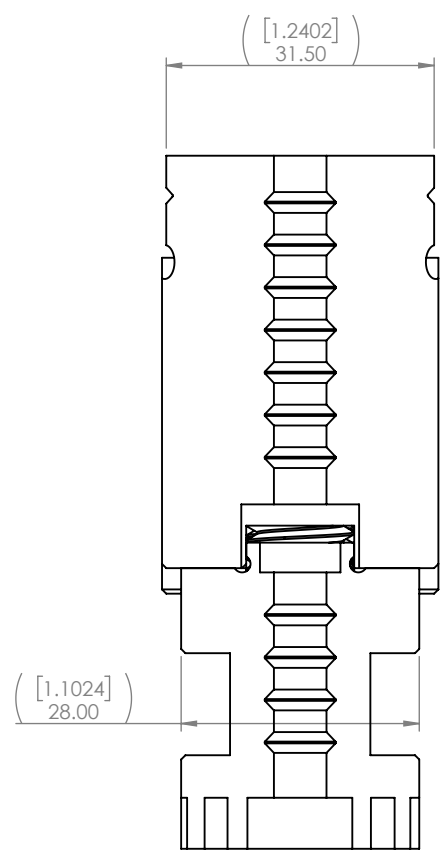
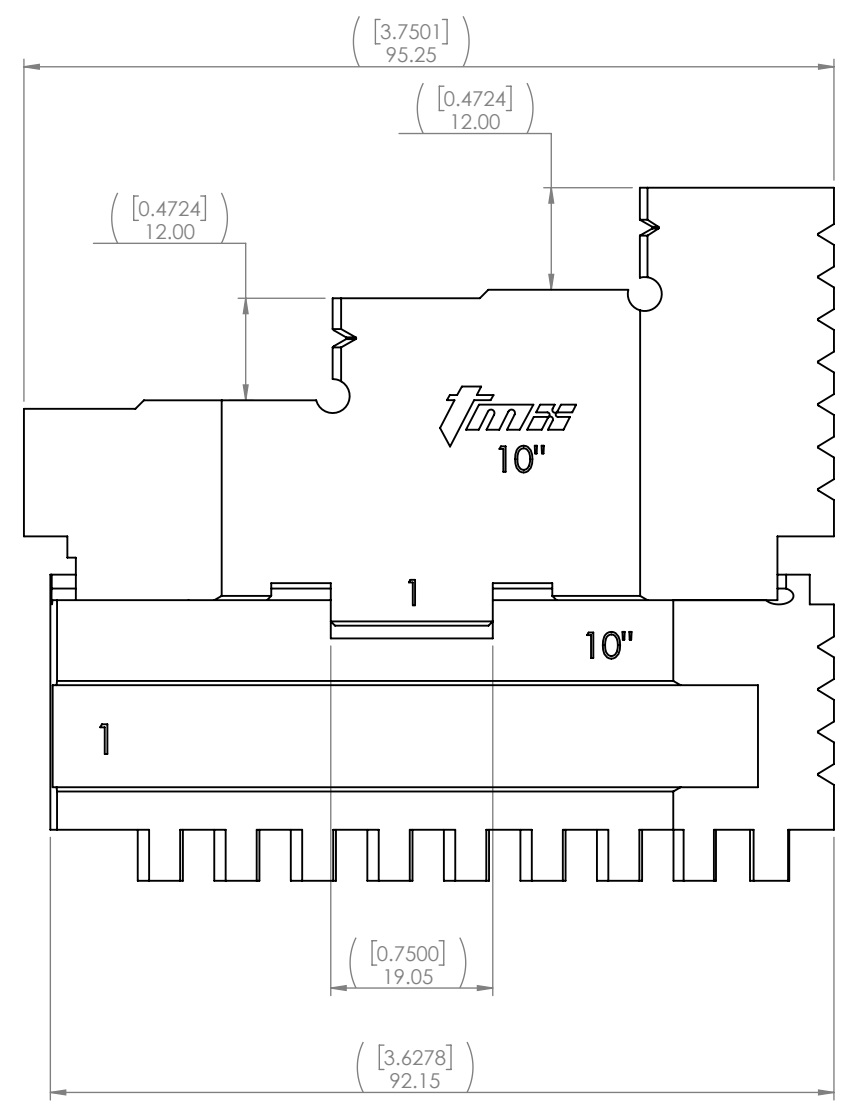
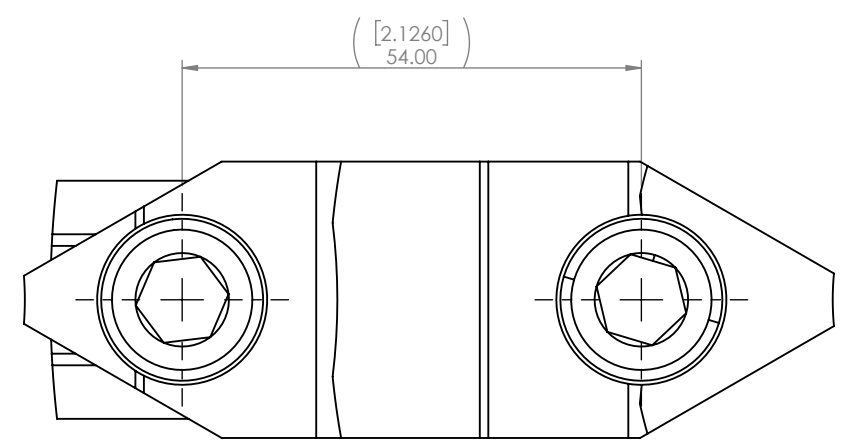

-CLICK ON LINKS BELOW FOR REPLACEMENT PARTS-

[3-883-610P, HARD TOP JAWS, 6IN, 6-JAW 6 PC SET](#)

[3-885-610P, HARD MASTER JAWS, 6IN, 6-JAW 6 PC SET](#)

MATERIAL:	SEE BOM	NAME	T. THACH	DATE	11-01-2024
HARDNESS:	N/A	FINISH:	N/A	DRAWN	T. THACH
<p>CONTACT INFORMATION: Toll Free 855-869-2425 Fax 508-653-5110 www.tmxtools.com 34 TALBOT ROAD NORTH BOROUGH, MA 01532 USA</p>			ENG APPR.	T. THACH	11-01-2024
<p>INTERPRET GEOMETRIC TOLERANCING PER: Y1999-2001</p>			MFG APPR.		
<p>THIRD ANGLE PROJECTION</p>			Q.A. APPR.		
<p>CONFIDENTIAL THIS DRAWING AND THESE SPECIFICATIONS ARE THE SOLE PROPERTY OF TOOLMEX INDUSTRIAL SOLUTIONS, AND SHALL NOT BE REPRODUCED, OR COPIED IN PART OR AS A WHOLE WITHOUT THE EXPRESS WRITTEN PERMISSION OF TOOLMEX INDUSTRIAL SOLUTIONS IS PROHIBITED.</p>			SALES APPR.		
<p>TOOLMEX™ SOLE PROPERTY OF TOOLMEX INDUSTRIAL SOLUTIONS</p>				TITLE	10IN, 6-JAW PLAIN BACK FRONT MOUNT SET-TRU SCROLL CHUCK
<p>SIZE DWG. NO.</p> <p>B 3-868-1000P</p>		<p>REV</p> <p>A</p>		<p>UNITS IN MILLIMETER</p>	
<p>DO NOT SCALE DRAWING</p>				<p>SHEET 3 OF 3</p>	

8 7 6 5 4 3 2 1